

ALUMINUM RAILING INSTALLATION INSTRUCTIONS



BALUSTER RAILING WITH CONTINUOUS TOP RAIL

ITEMS REQUIRED FOR INSTALLATION:

- Post-to-Surface Mounting Screws
- Cordless Drill/Driver
- Pencil
- Safety Glasses
- Miter Saw W/Non-Ferrous Blade
- Level
- Tape Measure
- 6" #2 Square Drive Bit
- 3/16" Drill Bit

IMPORTANT NOTES:

- Do not install base plate covers until railing assembly is completed.
- If installing lighting, wiring must be installed prior to securing posts to deck surface and installing top rail snaps.
- Actual picket panel lengths: 6' Panels = 69.43"; 8' Panels = 91.31".
- 3" posts are required to reach 6' & 8' lengths.
- MAX. POST SPAN ON STAIR RAILING APPLICATIONS IS 70" ON CENTER.
- Stair railing panels are shipped at a 37° angle. Panels are adjustable and will accommodate 30-40° stair angles. **CAUTION:** Over adjusting stair panels will cause loose and rattling pickets.
- 42" post kits are required for middle and bottom stair posts with the 36" railing system.
- 48" post kits are required for middle and bottom stair posts with the 42" railing system.
- 45° deck angles require 22.5° clips applied to each side of the post. The 22.5° clip kit is sold separately.
- Two 3" posts are recommended on top of deck surface if stair riser is not at a 90° angle from deck frame.
- It is the responsibility of the installer to meet all local code requirements and obtain all required building permits. The installer should determine and implement appropriate installation techniques for each installation situation. The manufacturer or its reseller shall not be held responsible for improper or unsafe installations.

(36IN HIGH SYSTEM SHOWN)

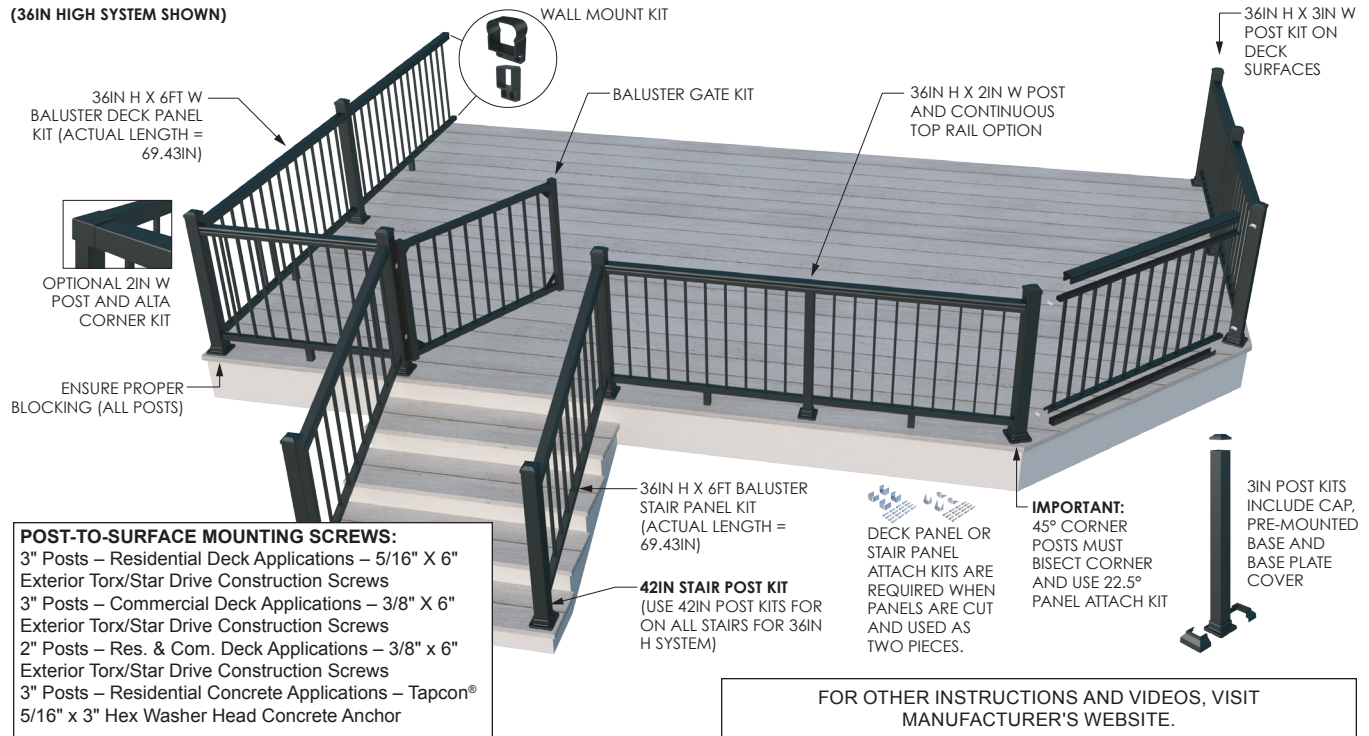

POST-TO-SURFACE MOUNTING SCREWS:

- 3" Posts – Residential Deck Applications – 5/16" X 6" Exterior Torx/Star Drive Construction Screws
- 3" Posts – Commercial Deck Applications – 3/8" X 6" Exterior Torx/Star Drive Construction Screws
- 2" Posts – Res. & Com. Deck Applications – 3/8" x 6" Exterior Torx/Star Drive Construction Screws
- 3" Posts – Residential Concrete Applications – Tapcon® 5/16" x 3" Hex Washer Head Concrete Anchor

STEP ONE – Determine necessary posts required and prepare (end, center or corner)

Install Lower Deck Rail Clips – Two Options:

Option A - When No Lower Rail Clip Jig Is Available

- Measure 2-7/8" from top of casting shoulder and place a pencil mark for location of the top edge of the rail clip. (Dia. #1)
- Center clip on post and secure with (2) - #8x3/4" Self-tapping screws.

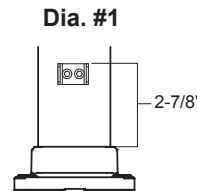

Option B - Using Lower Rail Clip Jig

- Place lower rail clip jig (w/ arrow facing base plate) on top of base plate upper edge. (Dia. #2)
- Place clip in hole and fasten with (2) - #8x3/4" Self-tapping screws.

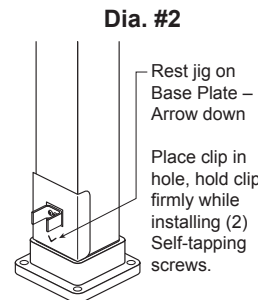

STEP TWO - Secure Posts to Deck

Install proper post blocking as per (Dia. #3a, 3b). Use proper attach screws or anchors as directed. (Deck screws at each post location, are not provided with kits).

- With 3/16" drill bit, pre-drill through deck boards and into blocking.
- Level and plumb post using shims.
- Secure posts to deck with suggested screws.
- Install post caps and base plate covers only after entire railing (including stair railing) is completed. (Dia. #4)

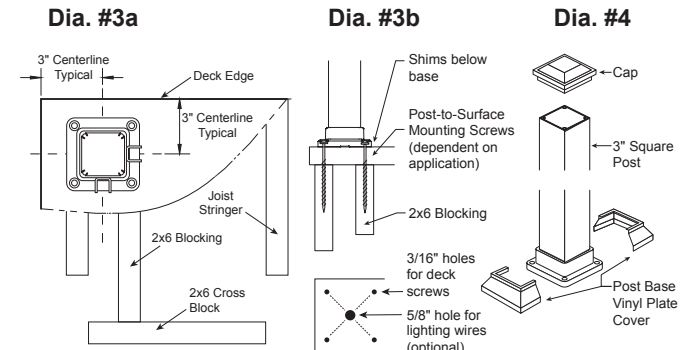

STEP THREE - Install Crossover Brackets in 2" Posts

- DECK APPLICATIONS: With #2 Sq. driver bit, fasten straight crossover brackets into posts with (2) - #8x1.5" Self-Tapping Screws. (Dia. #5A)
- If using 90° or 45° corner kits with 2" posts, install corner brackets from kits into 2" corner posts with (2) - #8x1.5" self-tapping screws (Dia 5C). Half crossover brackets may also be used at the end of handrails on 2" posts and include end caps.
- Note: In all crossover, half crossover and corner brackets, self-tapping screws must be installed in screw chases in-line with panels. Leave these screws slightly loose for ease of install. They will be tightened later.
- STAIR APPLICATIONS: See stair panel section for how to measure and cut 2" stair posts prior to installing crossover brackets.

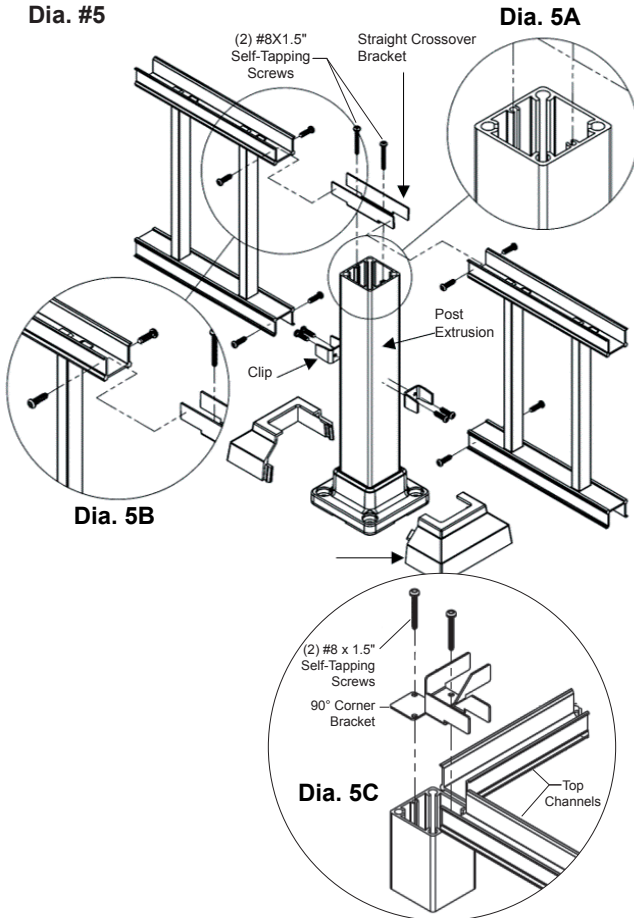

STEP FOUR - Cut Deck Panels

- Clamp or hold panel against post, adjust for equal end spacing. (Dia. #6)
- Mark the top and bottom rails.
- Cut panel 1/16" less than opening size.
- Clean cut areas and apply touch-up paint on exposed ends.

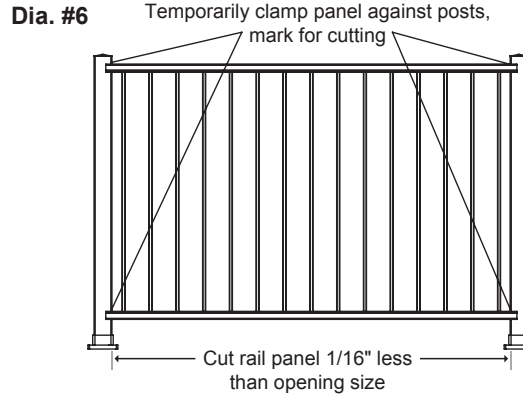

STEP FIVE - Secure Deck Panels to Posts

- Where panels meet a 3" post, slide bottom channel of pre-cut panel on to lower clip and insert a clip into top channel of panel (Dia. #7).
- Where panels meet a 2" post, slide pre-cut panel between lower clip and crossover bracket (Dia. 5B).
- Tighten the (2) - #8x1.5" Self-Tapping Screws in the crossover bracket.
- Using (4) - #8x3/4" Self-tapping screws, attach the upper clip(s) to the post.
- Using (8) - #8x3/4" Self-tapping screws, secure the upper and lower clips to the panel.

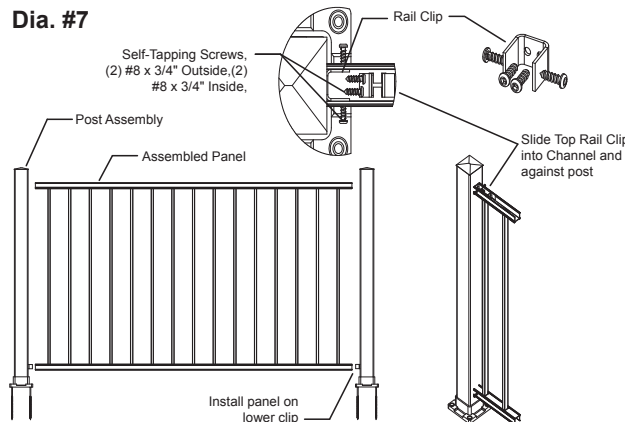

STEP SIX - Cut and Install Top and Bottom Rail Snaps

- For Top Rail Snaps, measure opening from corner post to corner post. Top rails terminating at a 90° post should be mitered at 27°, and should be cut to length to not interfere with bracket screw head. (Dia. #5C) At top rail locations which meet an end post (half crossover bracket), top rail covers should be cut straight and 1/16" less than opening.
- Measure between posts at the bottom. (Dia. #8)
- Cut bottom rail covers 1/16" less than opening.
- Clean cut areas and apply touch-up paint on all exposed metal.
- Snap each rail cover over the corresponding rail channel until properly seated. TIP: If top cover will not seat, try installing support legs. Then apply pressure to cover starting from one end.

Dia. #8

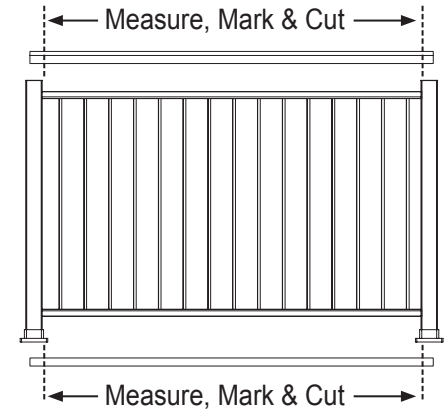

STEP SEVEN - Install Railing Corner Caps and End Caps

- Before applying adhesive, test corner caps to ensure proper fit.
- Apply metal-to-metal adhesive to top rail ends. Press firmly down on corner caps for as long as recommended by adhesive manufacturer. (Dia #9)
- Insert Handrail End Caps into end of handrails. Gentle bumping with the palm of a hand will push the end caps into the top rail. Metal-to-metal adhesive may be used as well.

Dia. #9

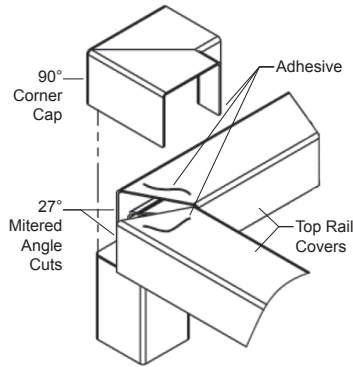

STEP EIGHT - Install Support Legs and Base Plate Vinyl Covers

- For openings greater than 4', install support legs under center of bottom rail (Dia. #10)
- Slide support leg under bottom rail and mark.
- Install two deck screws at location of support leg and install support leg over screws.
- Using (1) provided color-matched #8x3/4" Self-tapping screw, secure the support leg to bottom rail. (Dia. #11)
- Install post caps and base plate covers only after entire railing (including stair railing) is completed.

Dia. #10

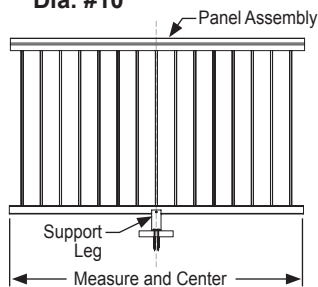

Dia. #11

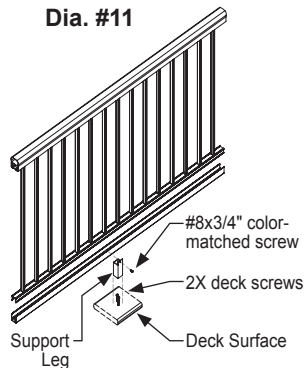

STAIR RAILING INSTALLATION

Prior to construction, check with your local regulatory agency for special code requirements in your area. Common residential stair railing height is 36". ADA secondary grab rail may be necessary to meet local code compliance. Stair post spans should never exceed 6' on center. For all other applications, consult a design professional or a manufacturer's representative for more information. Read installation instructions thoroughly before proceeding with assembly.

TIP: It may be helpful to leave posts loosely attached to stair treads while installing clips and panels.

STEP ONE – Fitting Stair Railing Panel

- Position stair railing panel alongside 3" top stair post and temporarily installed 3" bottom post (Dia. #12).
- Position stair panel approximately 1-1/2" above stair nosing. *Tip - lay a 2x4 board flat on nose of stair treads. This will allow enough room for installation of bottom snap. Clamp stair panel against top and bottom 3" posts. Using a sharp #2 pencil, mark the stair channels at four (4) locations.
- After panel has been clamped to post, mark cut lines on the H-channel and the 2" Stair Posts using the bottom of the H-channel to find your angle for post cut. (Dia. #13)
- Remove clamps and cut stair panel 1/16" less than opening at all four (4) locations. (Dia. #14A) Take care to cut stair channels at appropriate stair angle. Use of Miter saw with a sharp non-ferrous blade is recommended.
- Cut 2" Stair Posts where marked, taking care to cut at appropriate stair angle and direction. (Dia. #13)
- With #2 Sq. driver bit, fasten stair crossover brackets into 2" Stair Posts with (2) - #8x1.5" Self-Tapping Screws. (Dia. #15) NOTE: Self-Tapping Screws must be installed in screw chases in-line with panels.
- Clean cut areas and apply touch-up paint on all exposed ends.

Dia. #12

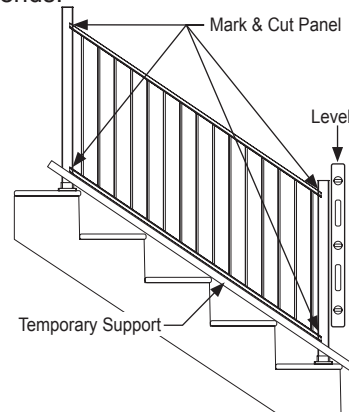

STEP TWO – Installing Stair Clips On Posts

- After stair panel has been cut to proper size and angle, place the panel on the 2x4 (or hold 1-1/2" above stair nosing) board, between two posts. Using a sharp #2 pencil, draw a line across the top of the lower picket channel, 2 places (Dia. #14B).
- Remove panel and bottom post. Fasten stair panel attach clips below marked lines with (4) #8x3/4" Self-tapping Screws. (Dia. #16)
- Repeat for each stair panel section.

Dia. #13

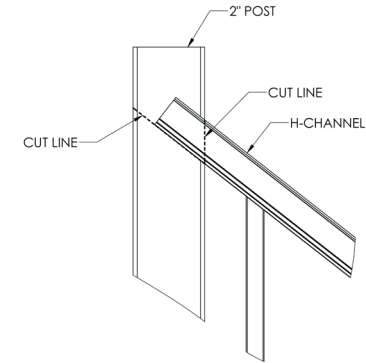

Dia. #14A

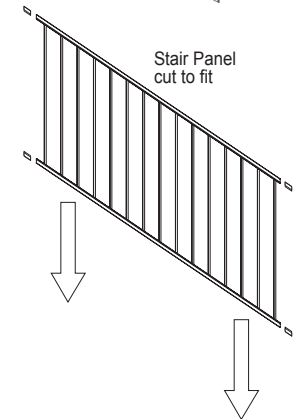

Dia. #14B

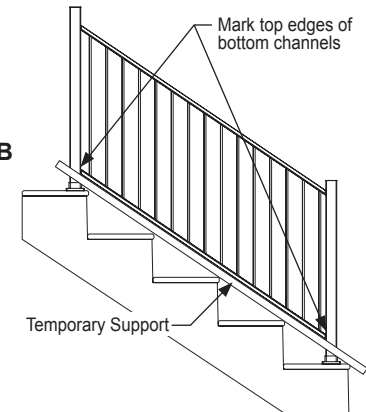

Dia. #15

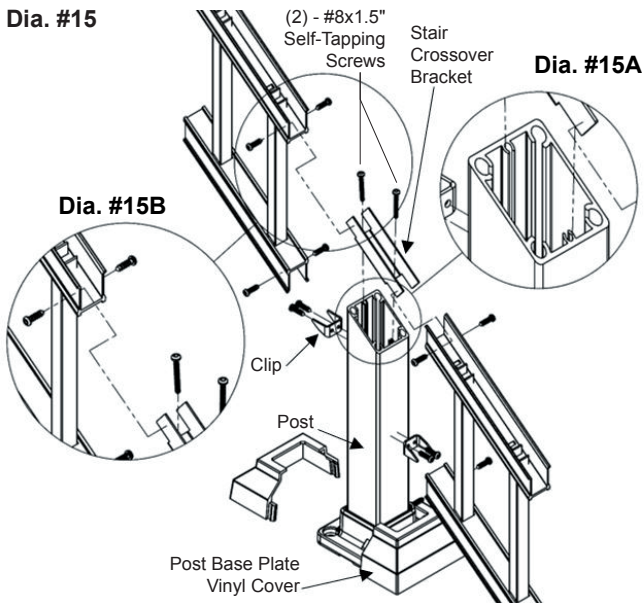

Dia. #16

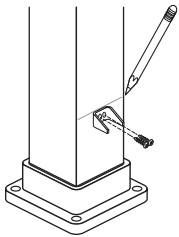

STEP THREE – Securing Stair Panel To Posts

- Once the stair panel attach clips have been installed, re-attach the lower (last) post to the bottom step or landing. Place the stair panel onto the lower stair panel attach clips (Dia. #17).
- When lower channel is fully seated on lower stair clips, insert stair panel attach clips into upper channel. (2" posts with crossover brackets do not need upper stair attach clips.) Secure upper stair attach clips to post with 2-#8x3/4" Self-tapping screws, then secure upper channel to stair panel attach clip with two (2) - #8x3/4" Self-tapping screws. Repeat this same procedure for bottom post, upper channel (Dia. #18).
- When upper channel is secured to attach clips, return to lower channel and secure lower channel to lower stair clips with two (2) - #8x3/4" Self-tapping Screws at upper post and two (2) - #8x3/4" Self-tapping Screws at lower post

Dia. #17

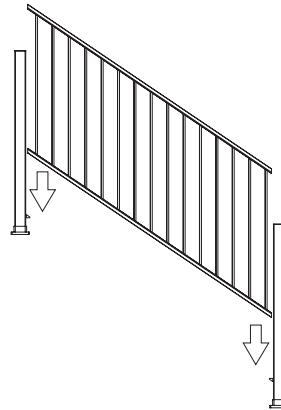

STEP FOUR – Install Top And Bottom Snap Covers and Base Plate Vinyl Covers

- Following the same angle as the secured stair panel, clamp or hold top/bottom rail snaps against 3" posts (Dia. #19). Using a sharp #2 pencil, mark the top/bottom rail snaps at all four (4) locations. Continuous Top Rail Snaps may span several panels up to a total of 18' in length.
- Remove clamps and cut top/bottom rail snaps at all four (4) locations. Take care to cut snaps at appropriate stair angle. Use of Miter saw with a sharp non-ferrous blade is recommended. Cut 1/16" less than opening size.
- Clean cut areas and apply touch-up paint on exposed ends.
- Snap each rail snap over the corresponding rail channel until properly seated (Dia. #20).
- Install post caps and base plate covers only after entire railing assembly (including stair railing) is completed.

Dia. #19

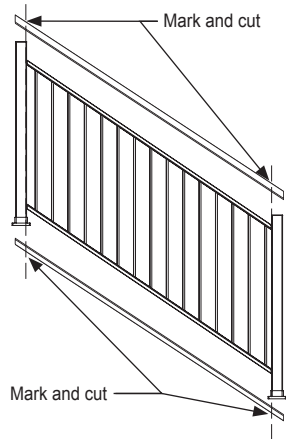

Dia. #18

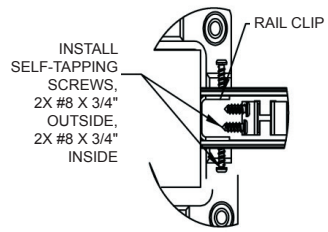

Dia. #20

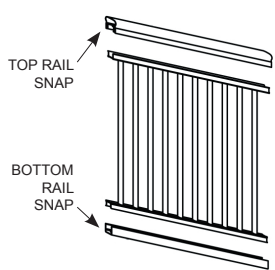

STEP FIVE – Installation Of ADA Compliant Hand Rail

ADA handrail may be required (Dia. #21) for residential deck installations (check with local building code official). Maximum recommended span between posts is 6' on center. See the manufacturer's ADA Railing Installation Instructions for all installation configurations.

Dia. #21

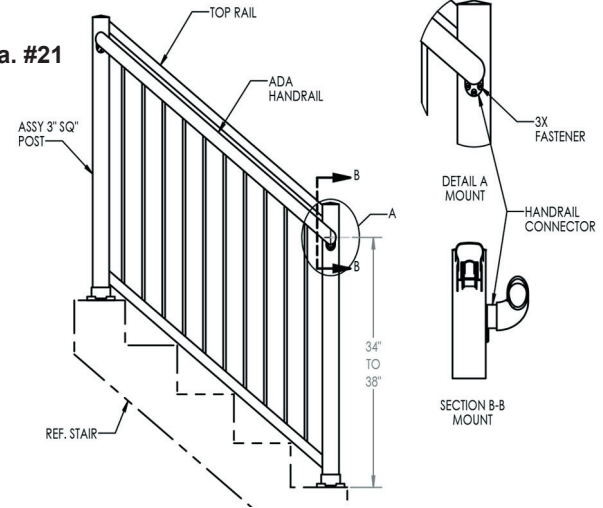

The diagrams and instructions in this brochure are for illustration purposes only and are not meant to replace a licensed professional. Any construction or use of the product must be in accordance with all local zoning and/or building codes. The consumer or contractor assumes all risks and liability associated with the construction or use of this product. The consumer or contractor should take all necessary steps to ensure the safety of everyone involved in the project, including, but not limited to, wearing the appropriate safety equipment. Except as contained in the written limited warranty, The manufacturer does not provide any other warranty, either express or implied, and shall not be liable for any damages, including consequential damages.