

4

3

2

1

REVISIONS - BALLOONS DENOTE CHANGES			
REV.	DESCRIPTION	DATE	APPROVED
A		4/21/2020	ZAG

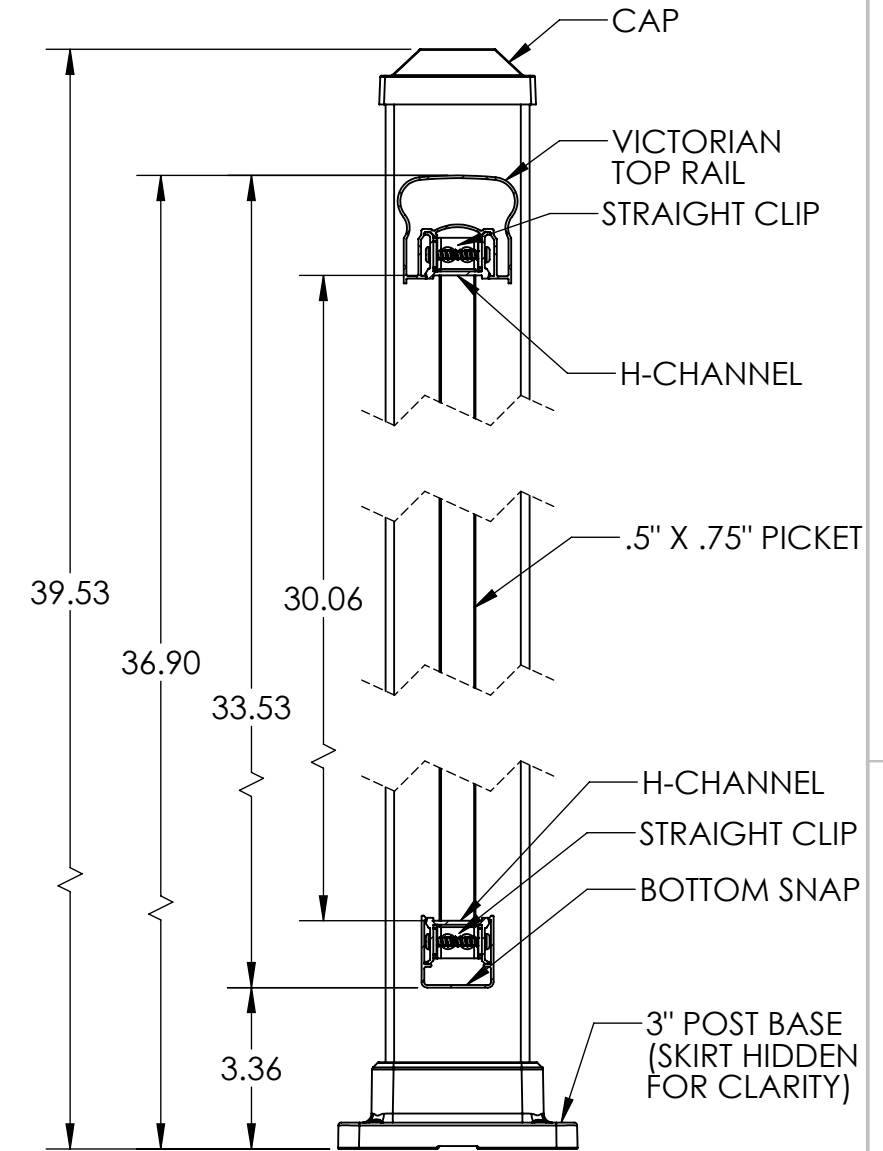
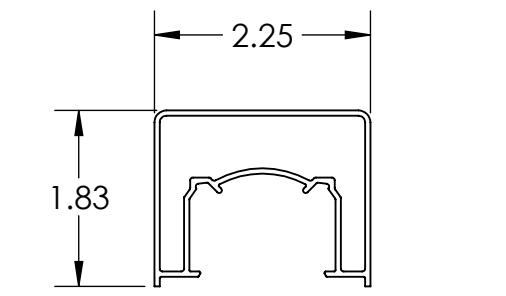
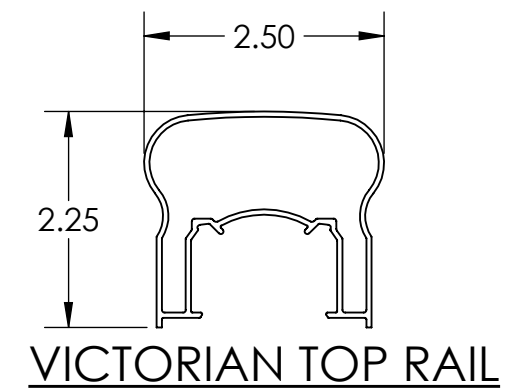
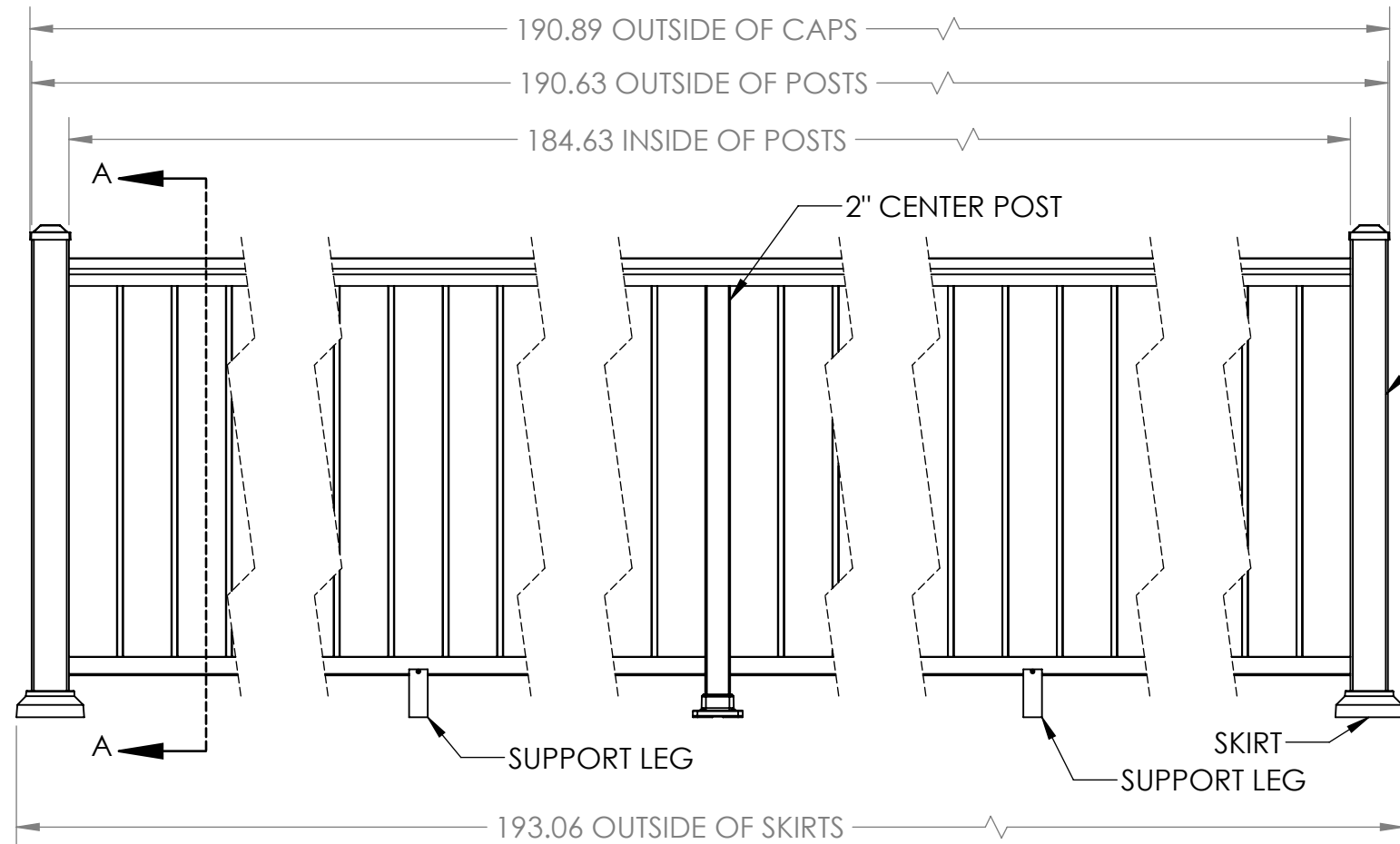

**SECTION A-A**

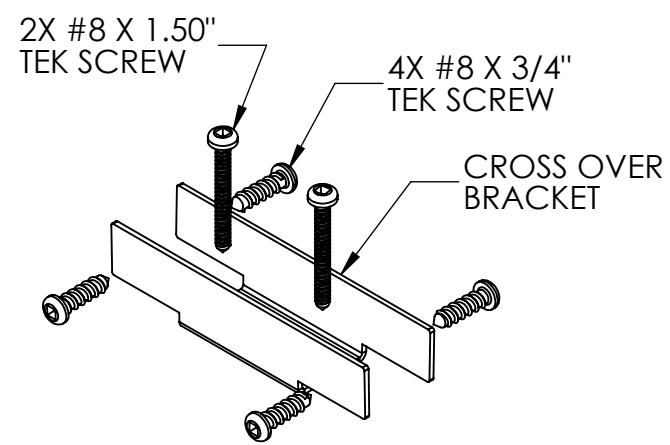

**1X 2" CROSS OVER BRACKET (MOUNTS ON TOP OF CENTER POST)**

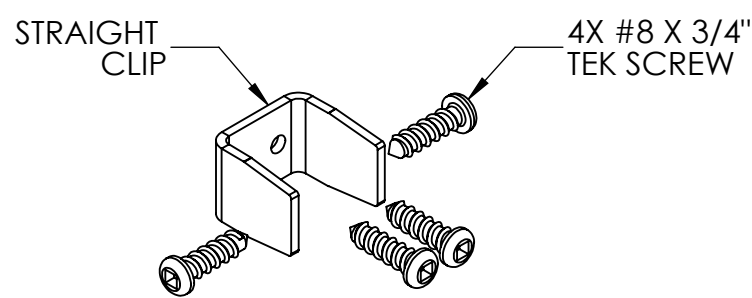

**6X CLIP DETAIL**

NOTES:  
 1. ALL RAIL MUST BE ASSEMBLED AND FASTENED IN ACCORDANCE WITH ULTRALOX'S INSTALLATION INSTRUCTIONS.  
 2. AVAILABLE COLORS ARE BLACK - WHITE - BRONZE.

UNLESS OTHERWISE SPECIFIED:		NAME	DATE
DIMENSIONS ARE IN INCHES		DRAWN	DRC 4/21/20
TOLERANCES:		CHECKED	
SURFACE FINISH: 125 RMS		ENG APPR.	
ANGULAR: ±.5 DEG		MFG APPR.	
LINEAR: .X ±.02		INTERPRET GEOMETRIC TOLERANCING PER: ASME Y14.5-2009	
.XX ±.010		THIRD ANGLE PROJECTION:	
.XXX ±.005		MATERIAL	
FINISH		PROPRIETARY AND CONFIDENTIAL	
DO NOT SCALE DRAWING		THE INFORMATION CONTAINED IN THIS DRAWING IS THE SOLE PROPERTY OF UltraLox. ANY REPRODUCTION IN PART OR AS A WHOLE WITHOUT THE WRITTEN PERMISSION OF UltraLox.	

		TITLE:
COMBINATION 36" TOP RAIL PICKET INFILL - 3" END POSTS 2" MIDDLE POSTS - BASE MOUNT 8' SECTIONS		SIZE DWG. NO.
REV <b>A</b>		WEIGHT:
SHEET 1 OF 1		

4

3

2

1